

Some aspects of energy methods for the inelastic seismic response of ductile SDOF structures

Michel Bruneau and Niandi Wang

Department of Civil Engineering, 161 Louis Pasteur, University of Ottawa, Ottawa, Ontario, Canada, K1N 6N5

(Received December 1993; revised version accepted June 1994)

This paper explores some aspect of energy demands for single-degree-of-freedom (SDOF) systems. Energy response time histories for simple pulses or sine-wave ground excitations are constructed and the behaviour of each contributing factor to the energy balance is studied. Examples are used to illustrate the fundamental behaviour of the kinetic energy, strain energy, energy dissipated through normal damping, energy dissipated through permanent deformations, and total input energy, the latter always being equal to the sum of the others throughout the dynamic response. It is found that: firstly, energy methods produce good indicators of the nonlinear inelastic seismic structural performance; secondly, the absolute energy method has some practical shortcomings, particularly regarding the definition of input and kinetic energies; thirdly, the relative energy method has a closer relationship to the parameters of engineering interest; and finally, if only hysteretic energy is of interest, both the absolute and relative energy methods can be used, unless normalization by input energy is sought.

Keywords: earthquake engineering, inelastic response, energy method, hysteretic energy, single-degree-of-freedom, time histories, pulse loading, sine, wave loading

1. Introduction

A number of design methods are currently available to assist structural engineers in providing earthquake resistant structures. The dynamic elastic modal analysis and static-equivalent lateral seismic force procedure typically recommended by most building codes are undeniably the most popular, although in some unusual circumstances, linear elastic or nonlinear inelastic time-history analyses are also used. All these methods essentially concentrate on establishing a peak demand for a particular design parameter, such as maximum displacement, ductility, and member forces. Other important aspects of seismic performance, such as cumulative cyclic ductility, number of yielding reversals, incremental collapse, low-cycle fatigue, energy dissipation capacity etc., are only indirectly considered in design by semi-arbitrary restrictions on the magnitude of the permissible strength reductions from the elastic-response level. For example, the 1990 edition of the National Building Code of Canada¹ uses a static-equivalent lateral seismic force specified as

$$V = (VeU)/R \quad (1)$$

where Ve is the equivalent lateral seismic force representing elastic response, R is a force modification factor, and $U = 0.6$ is a calibration factor. This design basis is essentially equivalent to an inelastic design response spectra where the permissible strength reduction R corresponds to a tolerated peak displacement ductility demand for a given type of structural system. However, the code-specified R values for various types of structural systems are set such that they only indirectly consider the particular cyclic ultimate performance germane to each system.

While safe and conservative, these current seismic-resistant design methods are implicitly addressing the needs of new construction. Therefore, when investigating the adequacy of existing structures against earthquakes, particularly in regions of low and moderate seismicity, traditional design and analysis methods may lead to overly conservative assessments of the demand as they fail to provide a comprehensive description of the required ultimate cyclic resistance. Unfortunately, no simple method cur-

rently exists which could be directly used by designers to this end.

Recently, energy-based methods have regained attention, and they could offer one possible solution to this problem (as well as to many others). These methods are based on the premise that the energy demand during an earthquake (or an ensemble of earthquakes) can be predicted and that the energy supply of a structural element (or a structural system) can be established. For a satisfactory design, the energy supply should be larger than the energy demand^{2,3}. Therefore, requiring less effort than complex nonlinear inelastic analyses, energy-based methods could provide more insight into the ultimate cyclic seismic performance than traditional design methods. However, much remains to be learned on seismic-related energy demands before these could be used in practice.

This paper explores some aspects of energy demands for single-degree-of-freedom (SDOF) systems, and, in particular, whether absolute or relative energy methods should be used. Starting from the basic idea that a typical dynamic earthquake excitation can be conceptually described as a complex sequence of pulses or sine waves of various durations, frequencies and intensities, energy response time-histories for simple pulses or sine-wave ground excitations are constructed and the behaviour of each contributing factor to the energy balance is studied. In a subsequent paper, using principles exposed herein, energy spectra will be constructed and a procedure to predict structural energy demand under real seismic excitation from the energy spectral results obtained for simple pattern excitations will be presented.

2. Energy methods: concepts

2.1. Literature review

An energy method to quantify seismic structural response was apparently first proposed by Housner⁴. He pointed out that a ground motion effectively feeds energy into a given structure, some of this energy being dissipated through damping and the remainder stored in the structure in the forms of kinetic energy (i.e. motion of the mass) and strain energy (i.e. deformation of the structural members). Based on the idea (in 1956) that a safe and economical seismic-resistant design should proceed through plastic analysis or limit-design, while allowing permanent deformations to occur without failure of a member, it was suggested that the design be tied to the concept of plastic energy, E_p , dissipated by structure and related to the inelastic deformation by

$$E_p = E_t - E_e \quad (2)$$

where E_t is the maximum kinetic energy which would be obtained if the structure behaved completely elastically, and E_e is the elastic energy of the structure when it reaches yield point. Although this energy equation was rudimentary, Housner's paper formulated the fundamental concept that at any instant the sum of the kinetic energy, strain energy, energy dissipated through normal damping, and energy dissipated through permanent deformation, must be equal to the total energy input. This provided the initial impetus to the later developments of energy methods in earthquake engineering.

Since the 1960s, the seismic nonlinear inelastic behaviour of structures has been paid considerable attention, but among the many researchers who addressed various aspects

of the earthquake-resistant design problem, few even considered the energy concepts proposed by Housner other than indirectly. However, in the 1980s, this trend reversed. In particular, McKeivitt *et al.*⁵ proposed a simple energy method for seismic structural design, Kato and Akiyama⁶ used an energy method based on Housner's equation⁴ for the design of steel buildings, Zahrah and Hall⁷ studied seismic energy absorption in SDOF systems, and Tembulkar and Nau⁸ investigated seismic energy dissipation capacity for inelastic modelling.

Uang and Bertero⁹ recently provided two mathematically consistent definitions of energy methods: they emphasized the physical meaning of each term in the energy balance equations and investigated the reliability of relative-energy and absolute-energy methods to predict the energy dissipation capacity of a given structural member or system. The subject subsequently attracted the attention of many researchers as evidenced by the recently published literature investigating energy-based concepts in earthquake-resistant design¹⁰⁻¹⁷. Since the energy method proposed by Uang and Bertero⁹ is clearly defined and has already received some acceptance, this paper essentially uses the same energy terms and definitions; these will be presented in a later section.

2.2. Single-degree-of-freedom inelastic dynamic equilibrium

The single-degree-of-freedom (SDOF) system is not only the simplest model of structural dynamics, but also the most fundamental model used in seismic response investigations. Its usefulness is foremost in the modal analysis of multiple-degree-of-freedom (MDOF) systems where complex structures can be decomposed into and analysed as a number of equivalent SDOFs. More importantly, however, concepts first formulated based on the study of SDOF systems have become the building blocks on which earthquake engineering is founded.

For a lumped-mass SDOF system subjected to a ground excitation, the equation of motion can be written as¹⁸

$$\ddot{u} + 2\omega\xi\dot{u} + \omega^2u = -\ddot{u}_g \quad (3)$$

where ω is the natural circular frequency of the system ($\omega^2 = K/M$), ξ is the viscous damping ratio which is equal to $C/2M\omega$ (and usually expressed as a fraction of the critical damping ratio), M is the mass of the system, C is its damping coefficient, and K its stiffness. Also, u , \dot{u} and \ddot{u} , respectively, denote the displacement, velocity and acceleration of the system relative to its base, and \ddot{u}_g stands for the ground acceleration relative to a fixed reference axis.

However, since buildings designed for code forces are expected to undergo inelastic response during earthquakes, the above equation can be rewritten in a nondimensional form as¹⁹

$$\ddot{\mu} + 2\omega\xi\dot{\mu} + \omega^2\mu = -\frac{\omega^2}{\eta} \frac{\ddot{u}_g}{\ddot{u}_{gmax}} \quad (4)$$

where the ductility ratio, μ , is defined by

$$\mu = u/\Delta_y \quad (5)$$

η is a strength ratio defined as

$$\eta = R_y/(M\ddot{u}_{gmax}) \quad (6)$$

and R_y and Δ_y are, respectively, the yield strength and yield displacement of a structural nonlinear inelastic behaviour model (for the bilinear elastoperfectly plastic model, these two latter parameters completely define this hysteretic model).

Hence, nonlinear systems having the same natural frequency, damping, hysteretic model, and strength ratio, η , will share the same ductility response if subjected to the same ground excitation. This response can be determined through simple analysis, and ductility spectra can be subsequently constructed¹⁹.

2.3. Uang and Bertero's absolute and relative energy methods

Uang and Bertero proposed two types of energy methods, based, respectively, on absolute and relative formulations of the energy equation. Each approach, although derived from the same equation of dynamic equilibrium for the SDOF system, leads to a specific and consistent set of energy terms and physical interpretations.

The absolute energy equation can be summarized as

$$E_i = E_k + E_d + E_a = E_k + E_d + E_s + E_h \quad (7)$$

The first term of the above equation is referred to as the 'absolute' kinetic energy, E_k , since the absolute velocity ($\dot{u}_i = \dot{u}_g + \dot{u}$) is used in its calculation, and is equal to

$$E_k = (M\dot{u}_i^2)/2 \quad (8)$$

The second term in equation (7) relates to the damping energy, E_d , which is

$$E_d = \int C\dot{u}^2 dt \quad (9)$$

and the third term in equation (7) is defined as the absorbed energy, E_a , which is composed of recoverable elastic strain energy, E_s , and irrecoverable hysteretic energy, E_h . Thus

$$E_a = \int F du = E_s + E_h \quad (10)$$

where E_s is equal to $F^2/2K$, F is the structural restoring force, and E_h is computed as the sum of the areas delimited by each loop traced by the force-displacement relationship of a system as it undergoes nonlinear inelastic response.

The left-hand side term in equation (7) is defined as the absolute input energy, E_i

$$E_i = \int M\ddot{u}_i du_g \quad (11)$$

since the inertia force, $M\ddot{u}_i$, applied to the structure is expressed in terms of the total acceleration relative to a fixed reference axis. This force is equal to the restoring force plus the damping force, and is also the total force applied to the structure's foundation. Therefore E_i represents the work done by the total base shear, $M\ddot{u}_i$, on the foundation's displacement, u_g .

The relative energy equation can be expressed as

$$E_i = - \int M\ddot{u}_g du = E'_k + E_d + E_s + E_h \quad (12)$$

where the 'relative' kinetic energy, E'_k , can be defined as

$$E'_k = (M\dot{u}^2)/2 \quad (13)$$

and all other energy terms are as defined above. Note that the relative structural velocity is used to calculate the relative kinetic energy, and that the left-hand term of equation (12) is the relative input energy, E'_i , which represents the work done by the equivalent static lateral force, $-M\ddot{u}_g$, on the relative displacement, u . A full derivation of these equations has been given by Uang and Bertero⁹. However, it is important to report that, based on the physical interpretation of these equations, Uang and Bertero have inferred that only the absolute energy method correctly embodies the physics of this problem, and should be used.

In both of the above methods, the input energy is always equal to the sum of the kinetic, damping and absorbed energies, i.e. energy balance always exists. This principle (the essence of all energy methods) has been used to assess the accuracy of calculations and validate computer results.

For example, using the above equations for an undamped linear elastic SDOF system with mass of M and stiffness of K subjected to a suddenly applied constant ground acceleration, the absolute kinetic energy is

$$E_k = \frac{M\ddot{u}_g^2}{2} \left(\frac{1}{\omega} \sin \omega t - t \right)^2 \quad (14)$$

The recoverable strain energy is

$$E_s = \frac{M\ddot{u}_g^2}{2\omega^2} (1 - \cos \omega t)^2 \quad (15)$$

The absolute input energy, by substitution of \ddot{u} and \ddot{u}_g into equation (11), is

$$E_i = M\ddot{u}_g^2 \left(\frac{t^2}{2} - \frac{t}{\omega} \sin \omega t - \frac{1}{\omega^2} \cos \omega t + \frac{1}{\omega^2} \right) \quad (16)$$

for at rest initial conditions, which indeed verifies the energy balance equation.

Similarly, the relative kinetic energy is

$$E'_k = \frac{M\ddot{u}_g^2}{2\omega^2} \sin^2 \omega t \quad (17)$$

and the relative input energy is

$$E'_i = \frac{M\ddot{u}_g^2}{\omega^2} (1 - \cos \omega t) \quad (18)$$

and the energy balance can still be analytically verified (i.e. the sum of E_k , E_d , E_s and E_h is equal to E'_i). It is noteworthy that for an undamped elastic SDOF system, the maximum E'_k is equal to the maximum E_s during the excitation.

Alternatively, instead of using a closed-form solution, a step-by-step numerical procedure can be adopted, and the energy balance is verified computationally provided the integration step is chosen to be sufficiently small. Any resulting imbalance reflects the inaccuracy of the calculations which can be remedied by further refinements in the size of the integration step. In this study, a linear acceleration step-by-step analysis procedure has been adopted, as

implemented in the NONSPEC nonlinear inelastic analysis computer program¹⁹.

3. Energy response to rectangular pulse excitation

Since a typical earthquake excitation could be interpreted as a complex sequence of pulses or sine waves of various durations, frequencies and intensities, structural responses to such simple patterns of dynamic excitations need to be studied first. This will allow the construction of energy spectra which could facilitate the prediction of structural energy demand under real seismic excitations, and also the identification of some valuable fundamental principles which could not be easily extracted and understood from the study of more complex excitations. Responses to simple impulses are investigated in this section, while responses to sine wave loading will be studied in the next section.

By comparing the maximum displacement responses of an elastoplastic SDOF system subjected to pulses of different shapes²⁰, it can be seen that the rectangular pulse excitation leads to the largest displacement response. Based on this, and for simplicity, the rectangular pulse loading has been selected for this study.

From the linear elastic solution of the equation of motion for a SDOF subjected to a rectangular impulsive load^{18,20}, it is well known that a maximum resulting displacement of $2M\ddot{u}_g/K$ will be obtained if a constant force is suddenly applied to this system and sustained for a sufficiently long time, i.e. exactly twice the value which would be obtained if the same force was applied statically. Using the notation previously presented, this implies that systems with $\eta \geq 2$ are ensured a linear-elastic response when subjected to a rectangular impulse.

3.1. Case studies on displacement and energy response time histories

Here, as well as in the next section, an arbitrarily selected rectangular pulse is used in the analyses. Its peak ground acceleration, \ddot{u}_{gmax} of 1 m/s², and duration, t_d of 0.5 s, are sufficient to define it. Normalization considerations to unconstrain the characteristics of this rectangular pulse excitation will be introduced in a subsequent paper.

It is also noteworthy that the ground velocity and displacement corresponding to a rectangular pulse are not base-corrected, contrary to most earthquake records. In theory, if base correction was performed to the rectangular pulse ground excitation, the velocity and displacement of the supporting foundation would return to zero at the end of the pulse, instead of being launched into a constant velocity motion once the pulse is over. Simple attempts to base-correct a constant amplitude rectangular pulse would rapidly demonstrate that it cannot logically be done. Only more complex forms of excitation, notably not producing a progressively increasing velocity throughout when integrated (like an earthquake excitation), can be base-corrected. However, at this point, to keep things simple, and because, as will be demonstrated later, only some less meaningful energy terms are somewhat affected by the absence of a base-corrected input time history, base-correction will be ignored in this paper.

To illustrate important conceptual differences in the energy response obtained when considering the relative or absolute energy criteria, a step-by-step inelastic time-his-

tory analysis is conducted for a SDOF system having an arbitrarily selected mass of 1 kg and subjected to the aforementioned pulse base-excitation. For this example, the structural period, T , of the SDOF is 0.5 s, and the strength ratio, η , is 1.0. To illustrate the impact of damping, the analysis is first conducted for the undamped system, and then repeated with a damping coefficient, ξ , equal to 2% of critical. The resulting relative displacement time histories, as well as all the absolute and relative energy time histories are presented in *Figures 1-3*. The individual input energy, kinetic energy, hysteretic energy and damping energy time history responses are displayed on the same plot to provide perspective.

3.1.1. Energy response: undamped example

For this SDOF system, the resulting displacement ductility ratio μ is 6.3. The structure responds elastically only when its displacement does not exceed the yield displacement. From the relative displacement history shown in *Figure 1a*, it can be seen that the SDOF system starts to behave inelastically at $t \approx 0.1$ s, and eventually oscillates elastically about a 'plastic residual offset' subsequently to the end of the excitation. It is obvious that, in this case, the maximum displacement ductility demand μ is a relatively good damage index reflecting damage to the structure when it exceeds its yield displacement. An absolute displacement time history has been presented elsewhere²¹. However, it should be noted that, since the base correction has not been done, the absolute displacement dominates in magnitude and progressively makes the relative displacement contribution to the total displacement imperceptible after the pulse excitation.

Both the relative kinetic and recoverable strain energies (*Figure 2a*) will first rapidly increase to reach at the onset of yielding, a maximum value which will be sustained for the remaining duration of the pulse loading. After termination of the pulse load, they will start to fluctuate in a reciprocating exchange of energy, in accordance with the classic free-vibration response of an undamped spring. In this phase of oscillation, when the structure reaches its maximum displacement, the strain energy is at a maximum, while the kinetic energy is zero. Alternatively, when the structure crosses the new static equilibrium point, the strain energy is zero, while the kinetic energy is at a maximum. In the absence of damping, the maximum values of the kinetic and strain energies remain equal and constant when the structure oscillates.

As the structure retains a plastic residual deformation at the end of the pulse excitation, the hysteretic energy reaches and remains at a maximum constant value (*Figure 2a*), which can be related to the relative displacement response. Note that the hysteretic energy is only due to the structural inelastic deformation.

As also shown in *Figure 2a*, the relative input energy is the sum of the relative kinetic, hysteretic and strain energies; damping energy is null here. Once the pulse excitation is over, it can be seen that the input energy does not change anymore.

In *Figure 3a*, results for the same SDOF system are presented, expressed in terms of absolute energies. For clarity a different vertical scale is used. There, the strain and hysteretic energies are identical to those in *Figure 2a*, but the kinetic and input energies are considerably different. Such differences between the absolute and relative kinetic and input energies are expected. For example, the equation of

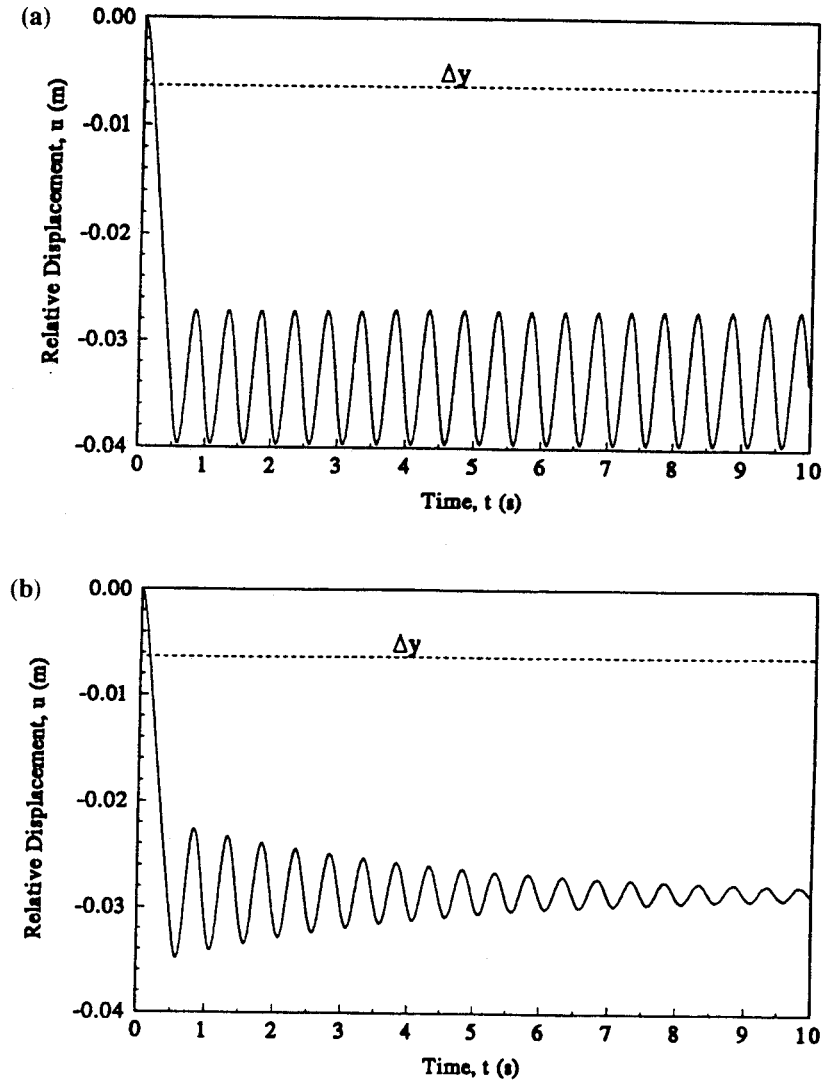

Figure 1 Relative displacement time histories for SDOF ($T=0.5$ s, $\eta=1.0$) subjected to rectangular pulse ground excitation: (a) undamped case ($\xi=0\%$); (b) damped case ($\xi=2\%$)

absolute kinetic energy is based on the absolute velocity, itself the sum of the relative velocity and the ground velocity (equation (8)); therefore the relative kinetic energy could be considered as just a subset of the absolute one. However, it is disconcerting to observe that the absolute input energy includes a free vibration phase which persists to fluctuate long after the termination of the pulse ground excitation (i.e. when there is no more input excitation). Moreover, in the free vibration range of response, the maximum value of kinetic energy is not equal to that of strain energy anymore, although energy balance still exists.

3.1.2. Energy response: damped example

Analysis of the above SDOF is repeated with a damping ratio, ξ , of 2%. In this case, the maximum displacement ductility ratio μ calculated is 5.5, slightly less than 6.3 obtained for the undamped case. Not surprisingly, as shown in Figures 1b, 2b and 3b, the displacement response, as well as kinetic energy and strain energy will progressively attenuate as a function of the damping ratio.

From the relative energy time histories (Figure 2b), it can be found that:

- All the nondamping energy values, including the relative input energy, are reduced by the presence of damping

- The damped-out relative kinetic and strain energies are converted directly to the dissipated damping energy
- The relative input energy remains constant after the excitation
- Also, as before, in order to follow the interconversion of kinetic and potential energy in the postloading range, when E_k is the maximum, E_s must be zero

The fact that the gradually damped out kinetic and strain energies are converted into damping energy, as observed in Figure 2b, can be easily explained mathematically by substituting equation (13) into equation (9). This gives

$$E_d = \int_0^t C \frac{2E_k}{M} dt = 4\omega\xi \int_0^t E_k dt \quad (19)$$

which states that the damping energy at time t equals the integral of the kinetic energy over the interval from 0 to t , multiplied by a constant. Thus, when the kinetic and strain energies are completely attenuated, the damping energy will have reached its maximum.

In the light of the important effect of damping on the overall energy distribution, a close scrutiny of the energy results is warranted, particularly when comparing Figures 2b and 2a. This influence of the damping is illustrated in

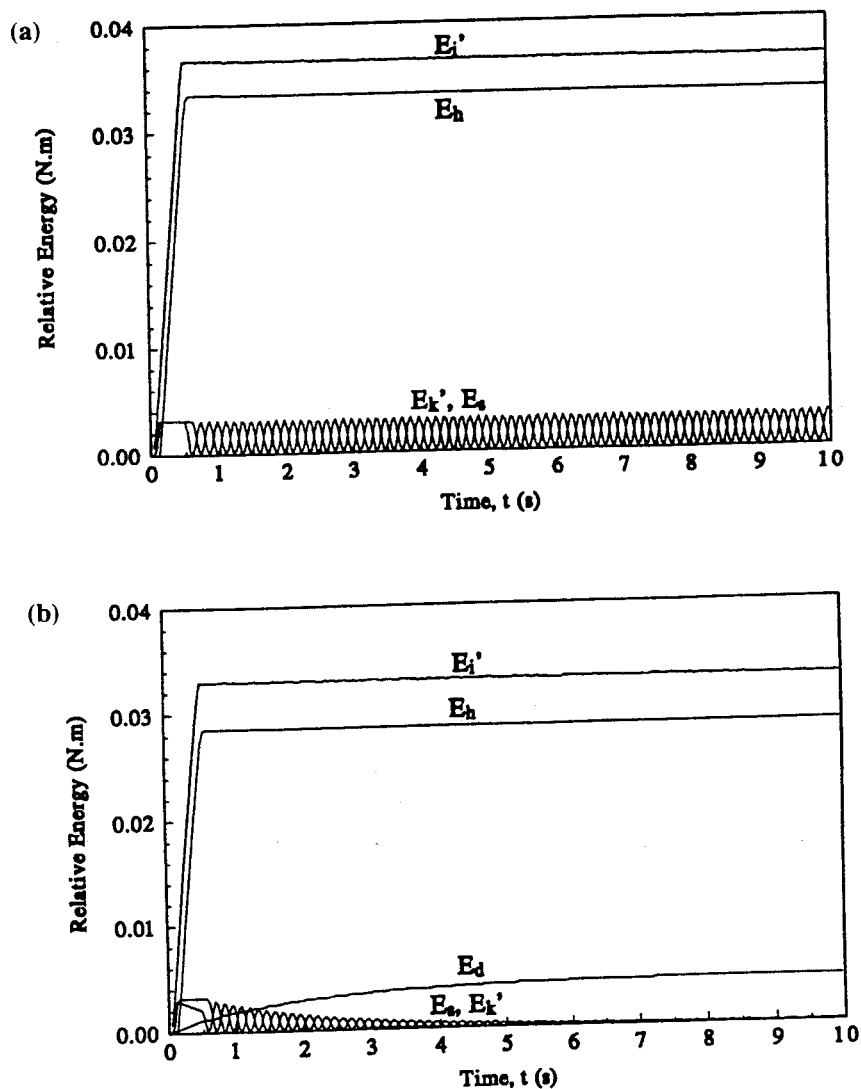

Figure 2 Relative energy time histories for SDOF ($T = 0.5$ s, $\eta = 1.0$) subjected to rectangular pulse ground excitation: (a) undamped case ($\xi = 0\%$); (b) damped case ($\xi = 2\%$)

Table 1 by comparing each energy value at a time of 0.5 s, 1.0 s and 10.0 s. These three time comparison points are selected as indicative of the structural response at three distinct stages: at the end of the pulse loading (0.5 s), and a short and long period of time after termination of the pulse excitation (1.0 s and 10.0 s, respectively). From Table 1, it can be observed that in the presence of 2% damping, there is approximately a 14% drop of the maximum sustained hysteretic energy dissipated by the system. Thus, small amounts of damping can significantly reduce the amount of the hysteretic energy dissipated by the structure.

The absolute energy time histories are also constructed in Figure 3b. Some observations can be summarized below:

- The strain, hysteretic and damping energies still remain the same as in Figure 2b
- All the nondamping absolute energies (Figure 3a) are also greater than those when damping exists (Figure 3b)
- As the nonbase-corrected ground velocity is used to calculate the absolute kinetic energy, E_k does not damp out as quickly as E_k' in the free vibration phase; instead, it fluctuates and finally converges to a constant value of 0.125 N.m which is equal to $M\dot{u}_g^2/2$ when the relative velocity reduces to 0

- The absolute input energy behaves like the absolute kinetic energy. After reaching a peak at the end of the excitation, it begins oscillating with decreasing amplitude and eventually levels off to a constant

Obviously, the hysteretic energy for the simple case of a system subjected to rectangular pulse excitation can be easily related to the maximum displacement ductility ratio spectra, largely because the nonlinear component of the response is not cyclic; displacement will reach a maximum value in one direction and then fluctuate within the elastic range around a plastic offset. Consequently, for a structural bilinear force-displacement relationship model, the hysteretic energy equation can be written as

$$E_h = R_y (u_{max} - \Delta_y) = R_y (\mu - 1) \Delta_y = (\mu - 1) ((\eta M \ddot{u}_{gmax})^2 / K) \quad (20)$$

where $u_{max} = \mu \Delta_y$, and $R_y = \eta M \ddot{u}_{gmax}$. Using this equation, hysteretic energy values can be checked against those in existing displacement ductility ratio spectra²⁰. For example, if the period of an undamped system with η value of 1.0 and mass of 1 kg is 0.5 s, its stiffness is then

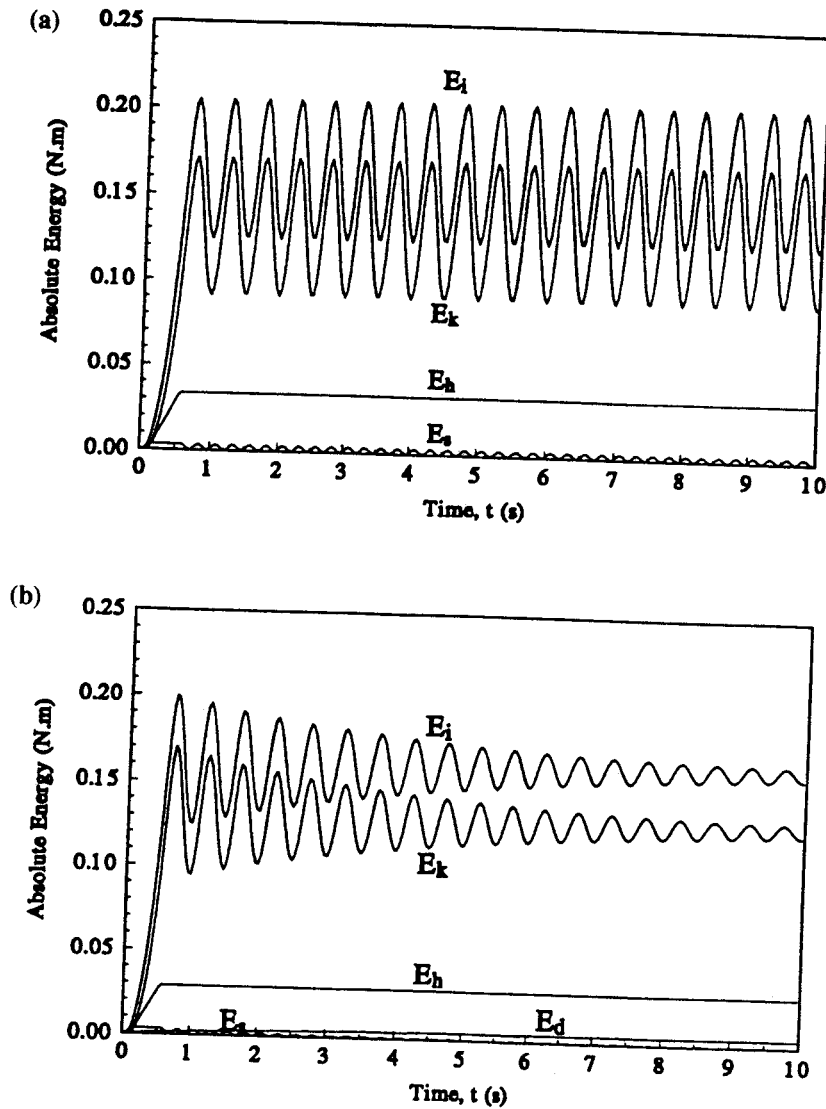

Figure 3 Absolute energy time histories for SDOF ($T = 0.5$ s, $\eta = 1.0$) subjected to rectangular pulse ground excitation: (a) undamped case ($\xi = 0\%$); (b) damped case ($\xi = 2\%$)

Table 1 Comparison of relative energies in undamped and damped example

Energy (Nm)	Time (s)					
	0.5		1.0		10.0	
	$\xi = 0\%$	$\xi = 2\%$	$\xi = 0\%$	$\xi = 2\%$	$\xi = 0\%$	$\xi = 2\%$
E_i	0.0361	0.0325	0.0366	0.0329	0.0366	0.0329
E_k	0.0032	0.0020	0.0025	0.0015	0.0030	0.0000
E_s	0.0032	0.0032	0.0007	0.0010	0.0002	0.0000
E_h	0.0298	0.0261	0.0334	0.0285	0.0326	0.0285
E_d	0.0000	0.0011	0.0000	0.0018	0.0000	0.0043

$$K = (2\pi/T)^2 M = 157.91 \text{ (N/m)} \quad (21)$$

The maximum displacement ductility ratio read from a pulse spectra, for such a system, is 6.0. Based on equation (20)

$$E_h = (6.0 - 1)(1.0 \times 1.0 \times 1.0)^2 / 157.91 = 0.0317 \text{ J} \quad (22)$$

which is indeed the value obtained in the above example.

In other words, existing pulse ductility ratio spectra for a bilinear inelastic force-deformation model can easily be converted into a hysteretic energy spectra for rectangular pulse loading. Hence, this implies that for rectangular pulse excitation, the hysteretic energy and displacement ductility ratio are equivalent structural damage indexes.

A few other such time history examples for SDOF subjected to pulse excitation, presented elsewhere²¹, confirmed the constancy of the above observations.

4. Energy response to sine wave excitation

In this section, the energy-related behaviour of SDOF systems subjected to sine wave excitation will be investigated. Again, the solution for the linear elastic response of a SDOF system subjected to harmonic loading is well known^{18,20}. Recall that, for an elastic system, the ratio of the resultant response amplitude to the static displacement which would be produced by the force $M\ddot{u}_g$ is called the dynamic magnification factor, D , and is given by

$$D = [(1 - \beta^2)^2 + (2\beta\xi)^2]^{-1/2} \quad (23)$$

where β is the ratio of frequencies of applied load to natural vibration frequency, ω/ω_n . At resonance ($\beta = 1$), the dynamic magnification factor is inversely proportional to the damping ratio, and is infinite for an undamped system.

In this section, an arbitrarily selected sine-wave ground excitation with amplitude of ± 1 m/s² and period of 2.0 s is used for all analyses. Again, normalization considerations will be addressed in a subsequent paper. It is noteworthy that the sine-wave ground motion selected is not base corrected either, and that, consequently the ground displacement will again increase throughout the time history. Although this has some influence on absolute input and kinetic energies as seen earlier, the other energy terms as well as the displacement ductility ratio are not affected by this. Since it is felt that these energy terms are not of major interest in earthquake-resistant design, base-correction would produce little additional valuable knowledge and has again been omitted.

Two examples are presented below to illustrate the typical response of SDOF systems subjected to the sine-wave ground excitation described above. For these examples, only relative displacement and relative energy response time histories are constructed since they have been shown to more vividly express structural behaviour. It should be noted that only undamped response is considered here. The effect of damping on energy responses is expected to be identical to what has been observed earlier.

In first example, β is 1 (i.e. the period of structure is 2.0 s), and η values of 9999 and 2.0 are considered to compare the elastic and inelastic resonant responses. In the second example, β is 0.75 (i.e. the period of the structure is now 1.5 s), and η values of 9999 and 2.0 are again used to obtain elastic and inelastic behaviour, respectively. The structural mass is arbitrarily taken as 1 kg for both examples.

4.1. Example with $\beta = 1.0$

Figure 4 compares the undamped relative displacement time histories of SDOF systems having the same period of 2.0 s, and η values of 9999 and 2.0, respectively. The elastic system with η of 9999, vibrates with an unbounded amplitude as expected for resonance¹⁸. However, for the inelastic system with η of 2.0, as soon as the yielding threshold is exceeded (here, for the assumed bilinear force-displacement relationship, Δ_y is 0.203 m), though β is still equal to 1, the response is bounded, i.e. the amplitude of vibration stops increasing after the first few cycles. Note that, for the inelastic system, the magnitude of the maximum value of displacement is asymmetric about the zero axis, as a consequence of plastic offsets of the at-rest position introduced by the presence of nonlinear inelastic excursions. This is well illustrated in Figure 5 for simple

structural hysteresis loops using the bilinear force-displacement relationship; there, it can be observed that for loading, unloading and load reversal cycles, the value of yield displacement is redefined either by deducting $2\Delta_y$, when unloading from the maximum positive inelastic displacement reached, or, reciprocally by adding $2\Delta_y$, to the minimum negative inelastic displacement reached when reloading. Moreover, in this case of constant-amplitude-sine-wave loading, the two redefined yield displacements do not change from their values of -0.0815 m and 0.1568 m, whereas the maximum and minimum displacements are also constant and equal to 0.3245 m and -0.2492 m, respectively, after a few cycles.

Figures 6 and 7 are the relative energy time histories for η of 9999 and 2.0, respectively. By comparing these two figures, the following can be observed.

- The elastic system has generally greater energy demands except for the hysteretic energy which exists only in the inelastic system. Note that Figures 6 and 7 are plotted in different scales
- For the elastic system, during the ground motion, the relative kinetic energy, E_k , and the strain energy, E_s , reciprocally fluctuate within the unbounded envelope of the input energy, E_i (Figure 6)
- For the inelastic system, in the presence of the hysteretic energy, E_h , during the excitation, the maximum values of E_k and E_s reached at each cycle remain stable, in agreement with what is expected by observation of the displacement time history in Figure 4, whereas E_h keeps increasing by a constant value for every half cycle of the sine wave loading (Figure 7). This behaviour of the hysteretic energy is substantially different than what was obtained previously for rectangular pulse excitation. The harmonic sine-wave ground acceleration excitation causes structural cyclic inelastic response and stabilizes it into a fixed pattern past the first few cycles of excitation
- It can easily be verified that the sum of two consecutive steps in the hysteretic energy time history is equal to the area under one hysteresis loop
- Energy balance still exists for both structures

4.2. Example with $\beta = 0.75$

Figure 8 shows the relative displacement time history of η of 2.0 and 9999. For η of 9999, the system behaves elastically with the resulting response being as predicted by theory¹⁸. Also, the system vibrates in a repeated pattern whose period is the least common multiple of the periods of the system and the sine-wave ground excitation.

When η is 2.0, the yield displacements in the reversed direction of the hysteresis loops are permanently offset to -0.0075 m and 0.0843 m, for the same reasons described in the previous example. The system rapidly becomes inelastic and the response pattern observed for the elastic system does not exist. The magnitude of maximum displacement is close to, but slightly less than that of the elastic system (when η is 9999).

Figure 9 shows the relative energy time histories for η values of 9999. The energy histories are bounded and exhibit a particular repetitive pattern. Since energies are related to the displacement response, the period of each pattern is also the least common multiple of the periods for the system and the load.

For $\eta = 2.0$ as displayed in Figure 10, the maximum

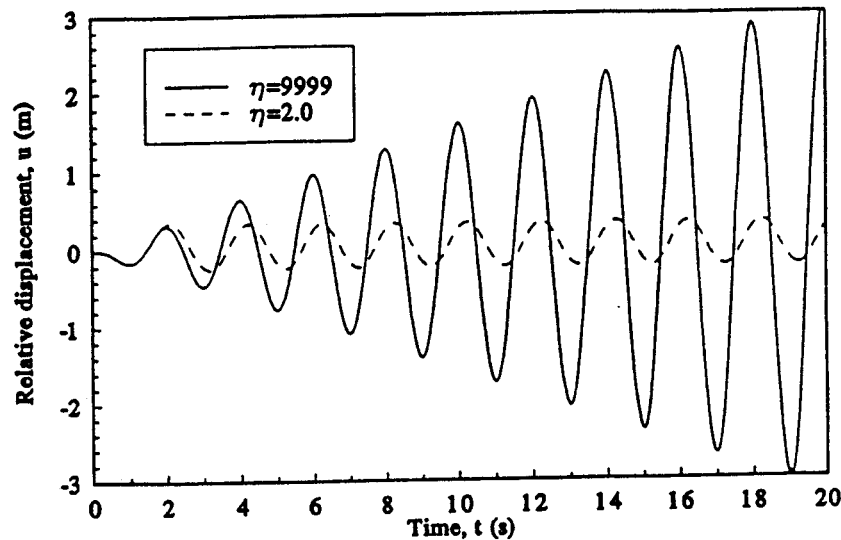
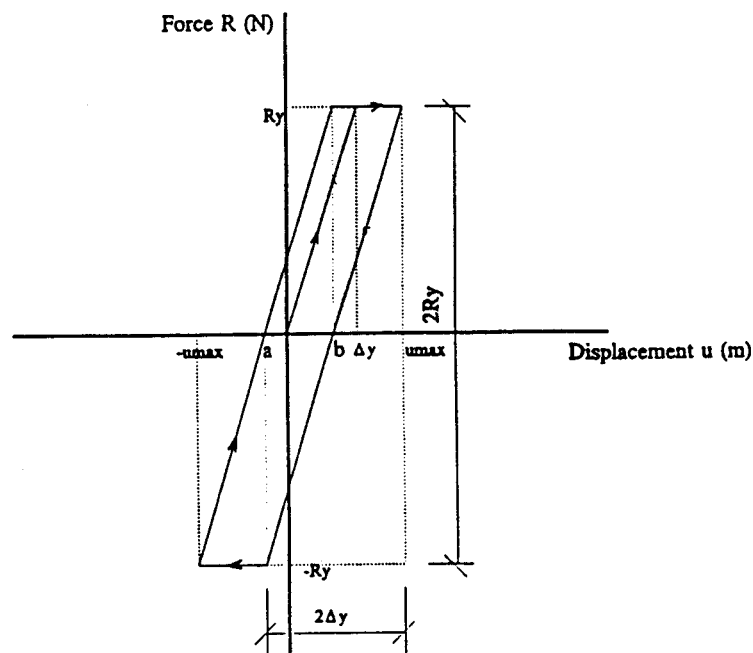

Figure 4 Relative displacement time histories for SDOF ($\beta = 1.0$ and $\xi = 0\%$) subjected to sine-wave ground excitation



- a — yield displacement of cyclic response for reverse loading;
- b — yield displacement of cyclic response for reloading.

Figure 5 Bilinear hysteresis loop model of SDOF subjected to sine wave loading

kinetic and strain energies are not so different from those obtained for the elastic system, while the resultant maximum input energy constantly grows as the hysteretic energy accumulates. By comparing Figure 10 with Figure 7, they are found to be of similar shape, although the growth of hysteretic energy per cycle is less, i.e. the area under each hysteretic loop is smaller than before.

5. Conclusions

Energy methods proposed by Uang and Bertero⁹ have been used to calculate energy demands of SDOF systems subjected to rectangular pulse and sine-wave ground excitations. Based on the simple case studies presented here, some valuable observations on energy methods for use in earthquake engineering are possible. Namely: energy

methods produce good indicators of the nonlinear inelastic seismic structural performance.

The absolute energy method, which has been promoted by some researchers as superior to the relative energy method, has some practical shortcomings as illustrated herein, particularly regarding the definition of input and kinetic energies. As illustrated in the case of pulse excitation, a conceptual paradox exists in that input energy can still fluctuate much past the end of the input (i.e. ground) excitation. The relative energy method, for its lack of such quirks and peculiarities but also for its close relationship to the parameters of engineering interest, seems a superior method.

Hysteretic energy, which reflects the cumulative nonlinear inelastic cyclic response, is by far, the most appropriate energy term to quantify the energy dissipation capacity of

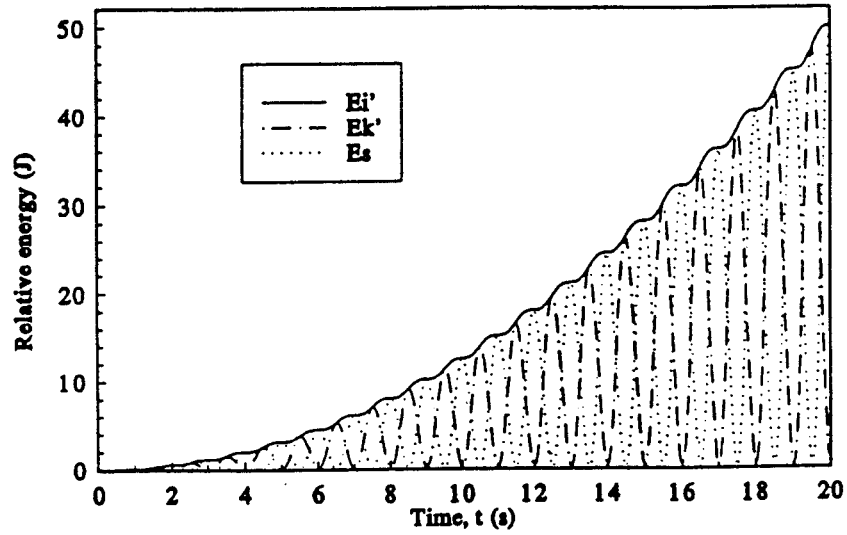

Figure 6 Relative energy time histories for SDOF ($\beta=1.0$, $\xi=0\%$, $\eta=9999$) subjected to sine-wave ground excitation - elastic response

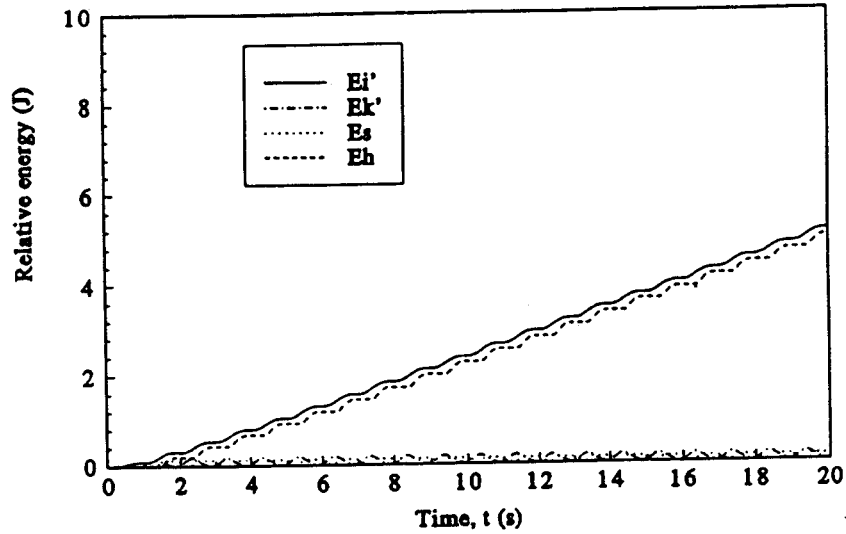

Figure 7 Relative energy time histories for SDOF ($\beta=1.0$, $\xi=0\%$, $\eta=2.0$) subjected to sine-wave ground excitation - inelastic response

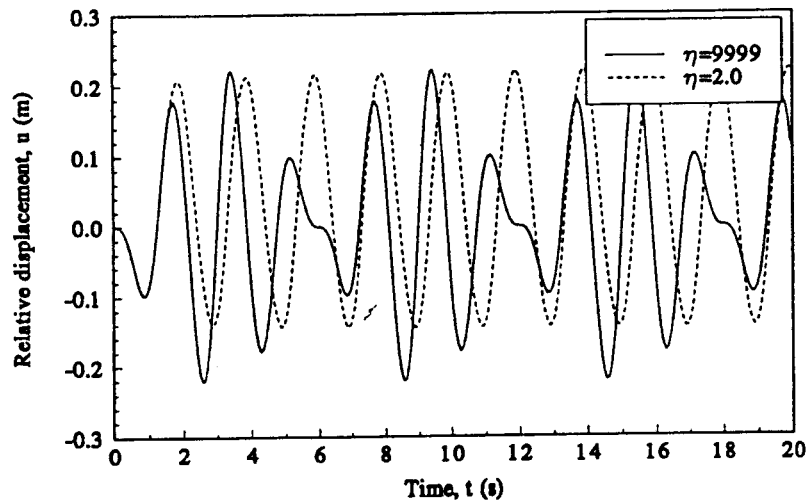

Figure 8 Relative displacement time histories for SDOF ($\beta=0.75$ and $\xi=0\%$) subjected to sine-wave ground excitation

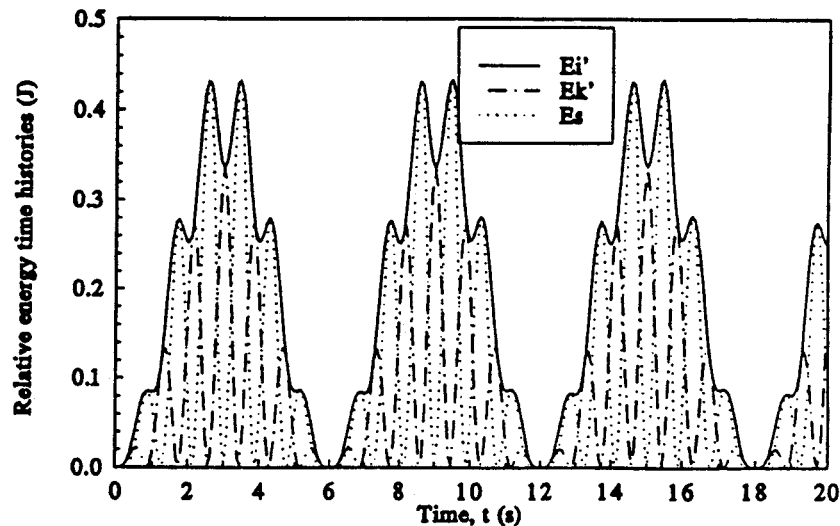

Figure 9 Relative energy time histories for SDOF ($\beta = 0.75$, $\xi = 0\%$, $\eta = 9999$) subjected to sine-wave ground excitation – elastic response

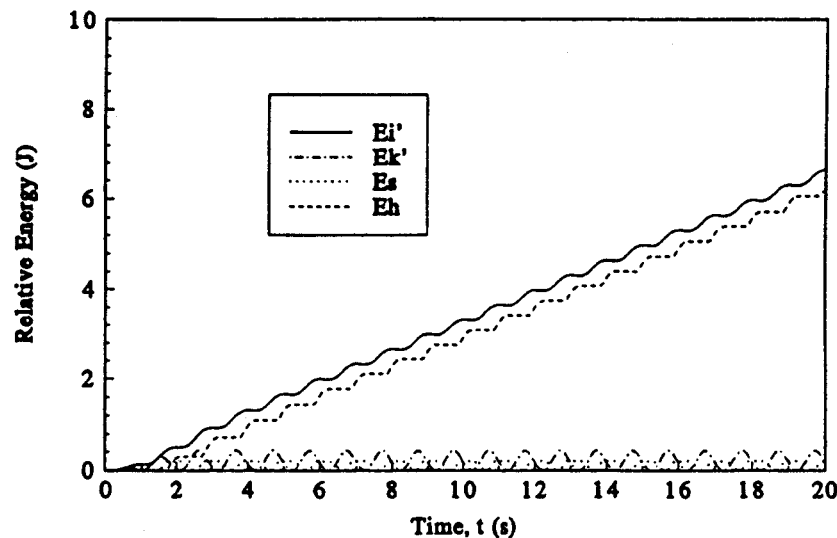

Figure 10 Relative energy time histories for SDOF ($\beta = 0.75$, $\xi = 0\%$, $\eta = 2.0$) subjected to sine-wave ground excitation – inelastic response

structures during earthquakes. This makes distinctions between the absolute and relative energy methods less critical.

Small amounts of damping energy can significantly reduce the amount of hysteretic energy dissipated by a structure.

These observations provide a useful perspective on the behaviour of various terms of the energy balance equations. This information is also valuable for the normalization efforts and other work presented in a subsequent paper.

Acknowledgments

Financial assistance provided by the Natural Sciences and Engineering Research Council of Canada is gratefully acknowledged. The findings and recommendations in this paper, however, are those of the writers and not necessarily those of the sponsor.

References

- NBCC, 'National Building Code of Canada 1990', National Research Council of Canada, Ottawa, 1990
- Housner, G. W. and Jennings, P. C. 'The capacity of extreme earthquake motions to damage structures', in *Structural and geotechnical mechanics*, (W. J. Hall, Ed.), Prentice Hall, Englewood Cliffs, NJ, 1977, pp 102–116
- Kuwamura, H. and Galambos, T. V. 'Earthquake load for structural reliability', *J. Struct. Engng. ASCE* 1989, **115**, 1446–1462
- Housner, G. W. 'Limit design of structures to resist earthquakes', *Proceedings of the First World Conference on Earthquake Engineering*, Berkeley, CA, 1956, pp 5:1–11
- McKevitt, W. E., Anderson, D. L., Nathan, N. D. and Cherry, S. 'Towards a simple energy method for seismic design of structures', *Proceedings of the Second U.S. Nat. Conf. on Earthquake Engineering*, 1979, pp 383–392. EERI
- Kato, B. and Akiyama, H. 'Seismic design of steel buildings', *J. Struct. Div., ASCE* 1982, **108** (ST8), 1709–1721
- Zahrah, T. F. and Hall, W. J. 'Earthquake energy absorption in SDOF structures', *J. Struct. Engng. ASCE* 1984, **110**, 1757–1772
- Tembulkar, J. M. and Nau, J. M. 'Inelastic modelling and seismic energy dissipation', *J. Struct. Engng. ASCE* 1987, **113**, 1373–1377
- Uang, C. M. and Bertero, V. V. 'Use of energy as a design criterion in earthquake-resistant design', Report UCB/EERC-88/18, Earthquake Engineering Research Centre, University of California, Berkeley, CA, 1988
- Conte, J. P., Pister, K. S. and Mahin, S. A. 'Influence of the earthquake ground motion process and structural properties on response characteristics of simple structures', Report UCB/EERC-90/09,

- Earthquake Engineering Centre, University of California, Berkeley, CA, 1990
- 11 Fajfar, P. and Fischinger, M. 'Earthquake design spectra considering duration of ground motion', *Proc. Fourth U.S. National Conf. Earthquake Engineering*, 1990, EERI, Vol. 2, pp 15-24
 - 12 Fajfar, P., Vidic, T. and Fischinger, M. 'A measure of earthquake motion capacity to damage medium-period structures', *Soil Dyn. Earthquake Engng* 1990, **9**, 236-242
 - 13 Léger, P. and Dussault, S. 'Seismic energy dissipation in MDOF structures', *J. Struct. Engng, ASCE* 1992, **118** (5), 853-858
 - 14 McCabe, S. L. and Hall, W. J. 'Assessment of seismic structural damage', *J. Struct. Engng, ASCE* 1989, **115**, (9), 2166-2183
 - 15 Uang, C. M. and Bertero, V. V. 'Implication of recorded earthquake ground motions on seismic design of building structures', Report UCB/EERC-88/13, Earthquake Engineering Research Centre, University of California, Berkeley, CA, 1988
 - 16 Uang, C. M. and Bertero, V. V. 'Evaluation of seismic energy in structures', *J. Earthquake Engng Struct. Dyn.* 1990, **19**, 77-90
 - 17 Wu, J. and Hanson, R. D. 'Study of inelastic spectra with high damping', *J. Struct. Engng, ASCE* 1989, **115**, 1412-1431
 - 18 Clough, R. W. and Penzien, J. *Dynamics of structures* McGraw-Hill, New York, 1975
 - 19 Mahin, S. A. and Lin, J. 'Construction of inelastic response spectra for single-degree-of-freedom systems', Report UCB/EERC-83/17, Earthquake Engineering Centre, University of California, Berkeley, CA, 1983
 - 20 Biggs, J. M. *Introduction to structural dynamics* McGraw-Hill, New York, 1964
 - 21 Wang, N. 'Normalized energy-based methods to predict the seismic ductile energy response of single-degree-of-freedom structures', M.A.Sc. thesis, University of Ottawa, Canada, 1993